

Willecke

Hebe- und Fördergeräte

www.willecke.de/en

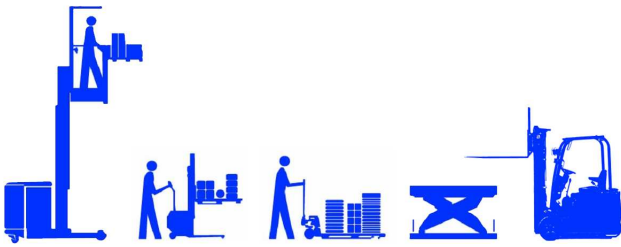



Willecke Hebe- und Fördergeräte GmbH · An der Becke 7 · D-45527 Hattingen



Lifting and handling equipment in your company

Dear ladies and gentlemen,

Do you make use of all possibilities of saving potential and to improve the effort of industrial trucks, elevated work platforms and ergonomic equipment in your company.

Trust in our successful experiences **since 40 years**

*** to solve your challenges regarding special transport and storage. ***

We concentrate on

* **Industrial trucks...**

* pallet trucks * pedestrian stackers * high lift stackers
* 4-way equipments * tool replacement trucks
* order pickers * very narrow aisle trucks

* **Lifting tables...**

* hydraulic scissor lifting tables * spindle scissor lifting tables
* low-profile lift tables ... for loading and equipments for production

and **special constructions...**

* lifting equipments for special demands.

We also offer individual consultations, financial support as well as customer service.

Our equipments are very sturdy and they are constructed for a long durability. In case of any problems we will make sure to help you and to find a contact person for maintenance and repair of your equipments.

Make use of our diverse experiences to your advantage. We are looking forward to your task and a successful cooperation with you!

Yours sincerely from Hattingen

Willecke
Hebe- und Fördergeräte GmbH

Jens Willecke

Willecke on the internet: www.willecke.de/en

Answer ----- by fax: 02324 / 39 112 - 22 or by e-mail: info@willecke.de ----- **answer**

Please send me an offer about: _____

Prospective circulars are also interesting for my colleagues: _____

Willecke Hebe- und Fördergeräte GmbH
An der Becke 7 (Gewerbegebiet Ludwigstal I)
D- 45527 Hattingen

Telefon +49 23 24 / 39 112 – 0
Telefax +49 23 24 / 39 112 – 22

E-Mail info@willecke.de
Internet www.willecke.de

Geschäftsführer Jens Willecke
HRB 15453
Amtsgericht Essen
USt.-IdNr.:
DE 226447643
Steuer-Nr.:
323/5879/0162

**Vertragshändler und
-kundendienst der**
Genkinger-HUBTEX
GmbH
u. a.
Mitglied im
CDH-Verband und
BVMW

Bankverbindungen
Sparkasse Hattingen (BLZ 430 510 40) Konto 3 004 173
IBAN: DE 66 4305 1040 0003 0041 73, SWIFT-BIC: WELA DE D1 HTG
Nationalbank Hattingen (BLZ 360 200 30) Konto 937 932
IBAN: DE 54 3602 0030 0000 9379 32, SWIFT-BIC: NBAG DE 3 E
Postbank Essen (BLZ 360 100 43) Konto 70 919 437
IBAN: DE 98 3601 0043 0070 9194 37, SWIFT-BIC: PBNK DE FF

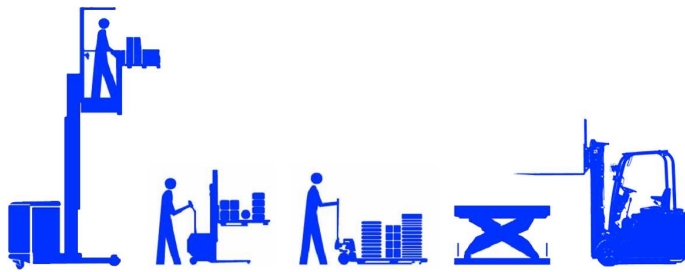

Contents

		Lifting and handling equipment in your company
		Contents
1	Industrial trucks (I.)	Pallet trucks, low-lift trucks, pedestrian stacker, high lift stacker
2	Industrial trucks (II.)	Tool replacement truck, tow tractor, four-way high lift stacker, sideloader, heavy duty equipment
3	Order pickers	Low level pickers, centre-mast order pickers, high level pickers, very narrow aisle trucks
4	Special industrial trucks (I.)	Tool replacement truck, assembly tables, handling equipment, high lift stacker with special heavy duty platform
5	Special industrial trucks (II.)	Car transporter, mandrel high lift stacker, roller grab, high lift stacker with hollow
6	Special industrial trucks (III.)	Charging wagon, reel grab, drum handling, pivoting crane arm
7	Special industrial trucks (IV.)	Drawbar tow tractor, equipment with crane arm, gripping, pivoting and tilting device
8	Special industrial trucks (V.)	Lifting platforms, traction drive, prism equipment, telescopic forks, heavy duty equipment
9	Special industrial trucks (VI.)	Sit-on low-lift truck, remote control, coil-transporter, sideloader, AGV-equipment
10	Ergonomic equipment	Minilifter, highlifter, sprinter high lift stacker, equipment for tilting boxes, scissor lift table
11	Special ergonomic equipment (I.)	Scissor lift trucks with roller bearing platform, roller conveyor, rotating platform, platforms for tipping, displacement platform
12	Special ergonomic equipment (II.)	Galvanized scissor lift trucks, with rotating platform, mini lifter with special platform, dustbin tipper
13	Special ergonomic equipment (III.)	Scissor lift trucks special platform, spindle belt, assembly lifting tables with special attachment
14	Lifting tables	Hydraulic lifting tables, push-chain lift, spindle lift, belt lift tables, assembly tables, pallet transfer station
15	Special lifting tables (I.)	Assembly tables, heavy-duty lifting tables, ex protected lifting tables, tilt lifting tables, loading lifting tables
16	Special lifting tables (II.)	double, triple, quadruple scissor lifting table, freight elevators, tandem lifting tables, lifting tables with big platform
17	Special lifting tables (III.)	Working lift tables with superstructures, assembly lifting tables, coil lift trucks, lifting tables with carriage
18	Special lifting tables (IV.)	Equipment for tilting boxes, lifting tables with traction drive or rather flanged wheels, fixed column lifts, work platform
19	Special lifting tables (V.)	loading lifting tables, lifting tables with tilting platforms, lifting tables for furnace charge, test desks
20	Stainless steel equipment	Stainless steel pallet truck, stainless steel high lift stacker, stainless steel scissor lift table, stainless steel lifting tables, ex protected equipment
A	Appendix	Index

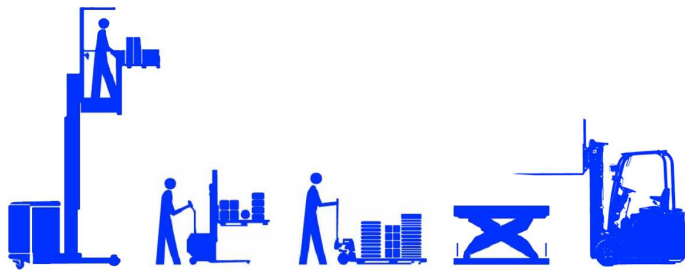

Your task – our solution: industrial trucks (I.)

Pallet trucks, low-lift trucks, pedestrian stacker, high lift stacker

For further information please have a look at our homepage on the internet: www.willecke.de/en



Pedestrian hand pallet truck



Electric pallet truck



Pallet truck with Driver's platform



Heavy duty electric low lifter (up to 8 to)



Sit-on low lifter



Stand-on low lifter



Foot-hydraulic pallet stacker



Electro-hydraulic pallet stacker



Electric high lift stacker with monomast



Electric pallet stacker



Electric high lift stacker with driver's platform



Electric pedestrian pallet stacker



Heavy duty electric high lift stacker (up to 6 to)



Self-supporting electro drawbar stacker



Stand-on pallet high lift stacker



Sit-on pallet stacker

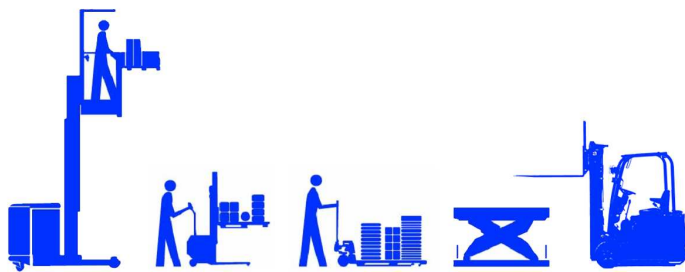

Your task – our solution: industrial trucks (II.)

Tool replacement truck, tow tractor, four-way high lift stacker, side loader, heavy duty equipments

For further information please have a look at our homepage on the internet: www.willecke.de/en



Manual tool replacement trucks



Electric tool replacement truck



Electric drawbar tow tractor



Heavy duty drawbar tow tractor (up to 20 to)



Electric low lifter with platform for special charges



Electric high lift stacker to pivot drums



4-way high lift stacker for long charges



4-way pallet stacker for long charges



Stand-on 4-way high lift stacker



Sit-on 4-way high lift stacker



Electric multi-way side loader



Electric side loader for long charges



Heavy duty industrial truck with platform for special charges (up to 8 to)



Heavy duty tool replacement truck



Heavy duty electric sit-on high lift stacker



Vertical order picker

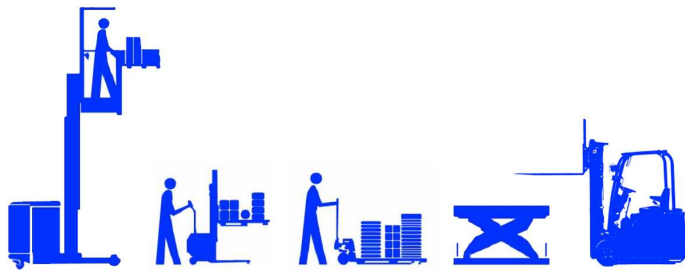

Your task – our solution: order pickers

Low level pickers, centre-mast order pickers, high level pickers, very narrow aisle trucks

Nähere Informationen zu unseren Geräten finden Sie im Internet: www.willecke.de/en



Electric low level picker



Electric order picker



Order picker



Electric order picker



Electric high level picker



Electric vertical order picker



High level picker with long forks



High level picker with platform



Very narrow aisle truck for charges up to 1,100 kg



Very narrow aisle truck for charges up to 1,200 kg



Very narrow aisle truck for charges up to 1,300 kg



Very narrow aisle truck for charges up to 1,500 kg



Very narrow aisle truck, lifting height up to 17 m



Very narrow aisle truck for charges up to 2,000 kg



Ergonomic seat



Very narrow aisle truck with telescoping fork

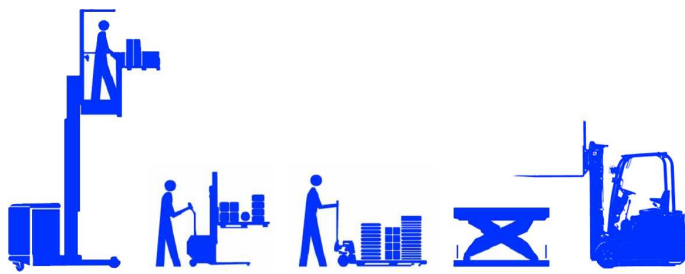

Your task – our solution: special industrial trucks (I.)

Tool replacement truck, assembly tables, handling equipment, high lift stacker with special heavy duty platform

For further information please have a look at our homepage on the internet: www.willecke.de/en



Tool replacement truck with pivoting platform



Tool replacement truck with roller conveyor



Tool replacement truck with roller bearing platform



Tool replacement truck with safety bolts



Tool replacement truck with roller bearing strips



Tool replacement truck with lowerable roller bearings



Electric changing system with telescoping boom



Assembly lift table for grand pianos



High lift stacker with double roller conveyor



High lift stacker for special tools



High lift stacker with double crane hooks



High lift stacker to assemble control cabinets



High lift stacker with mandrel



High lift stacker with tool changer



High lift stacker with telescoping forks for charges



High lift stacker for boxes

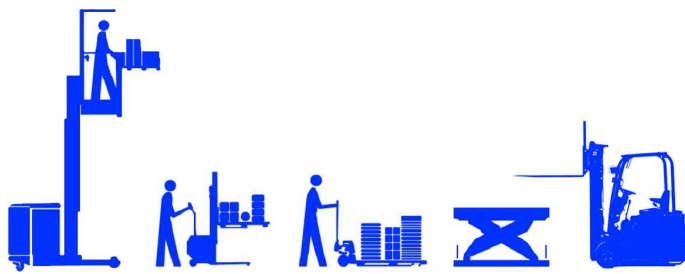

Your task – our solution: special industrial trucks (II.)

Car transporter, mandrel high lift stacker, roller grab, high lift stacker with hollow

For further information please have a look at our homepage on the internet: www.willecke.de/en



Electric low-lift truck to transport cars



Electric low-lift truck to transport cars



Heavy duty pallet truck for dilution tanks



Electric high lift stacker with carrying mandrel



Electric high lift stacker with hollow to carry reels



High lift stacker with expanding mandrel



Electric high lift stacker with pivoting mandrel



Electric high lift stacker with reel manipulator



Electric high lift stacker with mandrel and . . .



. . . push off/push unit



Electric high lift stacker with telescoping boom



High lift stacker to grab rollers



4-way high lift stacker with reel grab



Equipment to lift out barrels



High lift stacker with hollow to pivot



High lift stacker with hollow to pivot

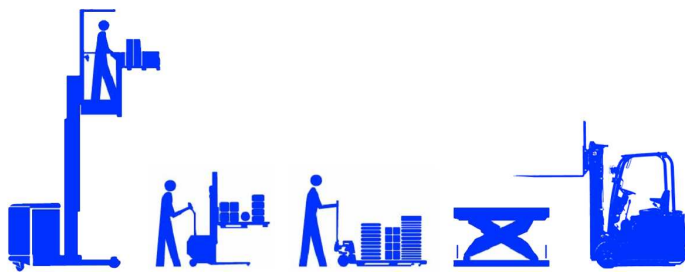

Your task – our solution: special industrial trucks (III.)

Charging wagon, reel grab, drum handling, pivoting crane

For further information please have a look at our homepage on the internet: www.willecke.de/en



Manual charging wagon



Manual electric charging wagon



Electric charging wagon



Electric charging wagon with roller conveyor



Electric lifting truck for loading ovens/Charging wagon with push off/push unit



Electric lifting truck for loading ovens/Charging wagon in action



Heavy duty electric charging wagon



Electric high lift stacker with double roller conveyor



High lift stacker with pipe grab



High lift stacker with hollow to tilt



Electric high lift stacker to grab and . . .



. . . pivot rolls

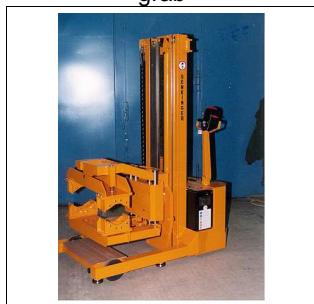

Electric high lift stacker with pipe grab



Electric high lift stacker with drum tipper



Electric high lift stacker with platform for heavy loads and gripping device



Electric high lift stacker with pivoting crane

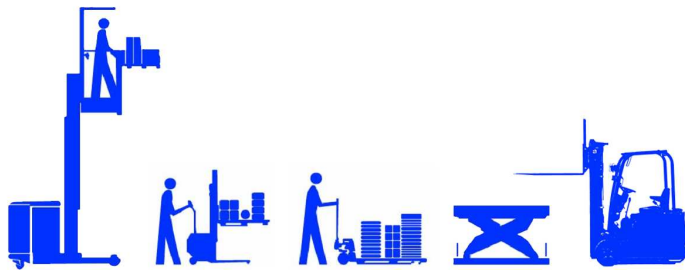

Your task – our solution: special industrial trucks (IV.)

Drawbar tow tractor, equipment with crane arm, gripping, pivoting and tilting device

For further information please have a look at our homepage on the internet: www.willecke.de/en



Electric drawbar tow tractor



Heavy duty electric drawbar tow tractor



Heavy duty electric drawbar tow tractor in action



Heavy duty drawbar tow tractor (up to 20t)

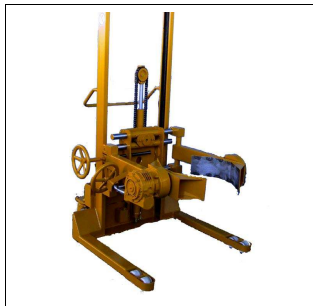

High lift stacker to grip and tilt



High lift stacker to grab bales



Electric high lift stacker with drum grab



Electric high lift stacker to grab drums



Electric high lift stacker with drum tipper



Electric high lift stacker with gripping device



Electric high lift stacker with crane arm



Electric high lift stacker with telescoping crane arm



High lift stacker to grab and pivot reels



Electric high lift stacker for annealing baskets



Electric high lift stacker to tilt lattice boxes



Electric high lift stacker to tilt containers

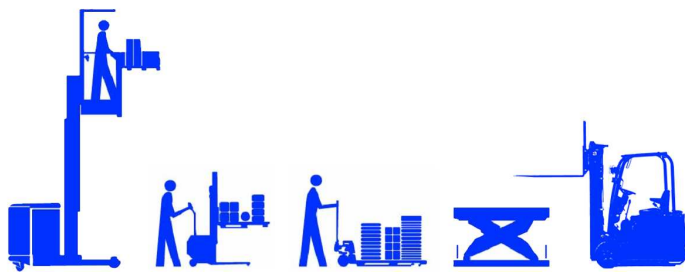

Your task – our solution: special industrial trucks (V.)

Lifting platforms, traction drive, prism equipment, telescopic forks, heavy duty equipment

For further information please have a look at our homepage on the internet: www.willecke.de/en



Fixed lifting work frame



Fixed platform lifting work frame



Electric pedestrian traction drive



Heavy duty electric pedestrian traction drive (up to 10to)



Electric sit-on traction drive



Heavy duty high lift stacker with prism surface



Electric high lift stacker with adjustable prism forks



High lift stacker with prism forks and power steering

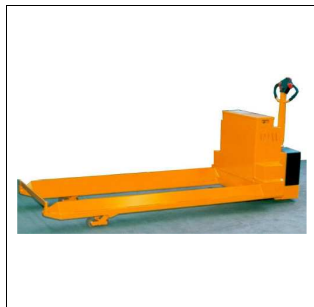

Electric low-lift truck with prism forks



Electric high lift stacker with telescoping forks



... lowered telescoping forks



Heavy duty electric low lifter



Heavy duty electric low lifter (up to 10to)



Heavy duty electric low lifter (up to 11to)



Heavy duty electric low lifter (up to 12to)



Heavy duty electric low lifter (up to 5to)

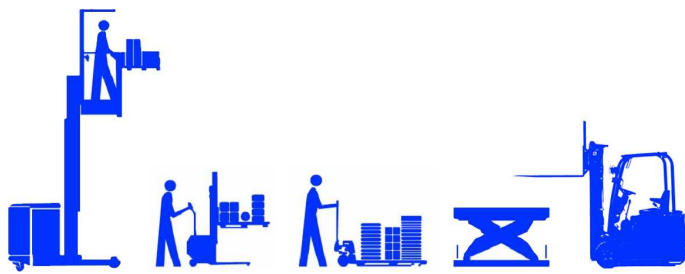

Your task – our solution: special industrial trucks (VI.)

Sit-on low-lift truck, remote control, coil-transporter, sideloader, AGV-equipment

For further information please have a look at our homepage on the internet: www.willecke.de/en



Electric sit-on low lifter



... with long forks



High lift stacker with straddle legs and remote control

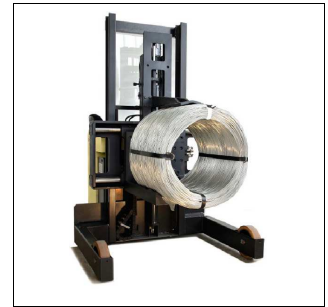

High lift stacker with straddle legs for coil transport



Coil handling double stack high lift stacker



Stand-on 4-way stacker for long charges



Electric stand-on reach truck ...



... for 4-ways / reach truck ...



.. best use off the aisle width, ...



... for medium-range operations,



... for long charges up to 8 m length



... as well as pallets up to 2.7t



Driverless electric pallet stacker



Operator panel of driverless electric pallet stacker



Driverless electric pallet stacker in action



Driveless electric pallet in use as pedestrian truck

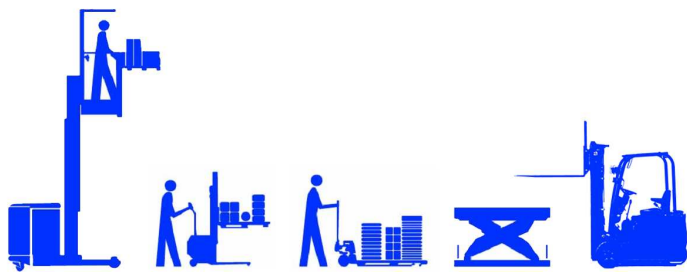

Your task – our solution: Ergonomic equipment

Minilifter, highlifter, sprinter high lift stacker, equipment for tilting boxes, scissor lift table

For further information please have a look at our homepage on the internet: www.willecke.de/en



Electric mini lifter with platform



Manual highlifter



Level control



Manual high lift stacker with straddle legs to load sprinters



Manual high lift stacker with straddle legs to load sprinters



Tilting lattice boxes and containers electrically



Tilting lattice boxes and containers with straddle legs electrically



Electric high lift stacker with side-tilting forks rotator



Scissor lifting table



Scissor lifting table



Scissor lifting table



Scissor lifting table



Scissor lifting table with roller conveyor



Scissor lifting table



Scissor lifting table



Scissor lifting table

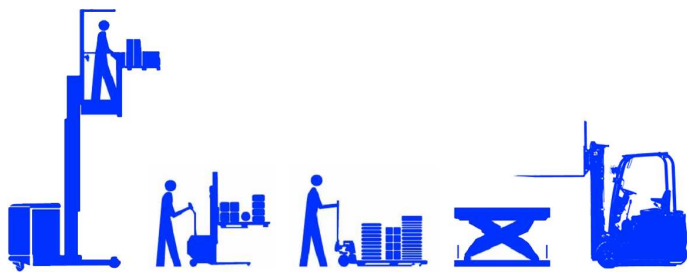

Your task – our solution: special ergonomic equipment (I.)

Scissor lift trucks with roller bearing platform, roller conveyor, rotating platform, platforms for tipping, displacement platform

For further information please have a look at our homepage on the internet: www.willecke.de/en



Lifting table with fork sleeves



Lifting table, 12V propulsion and roller conveyor



Lifting table with bearing platform



Ex lifting table with 4 steering rollers



Lifting table with bearing platform



Manoeuvrable pallet truck with double roller conveyor



Lifting table with hand pump



Assembly lift table with pivoting platform



Pneumatic powered table with bellow



Lifting table, attachment for expanding shafts



Desk on lifting table



Manual working platform for joinery



Mobile lifting table with tilting platform



Lifting table with tilting platform



Manual pedestrian table with bellow and pivoting platform



Manual pedestrian table with bellow and platform to move

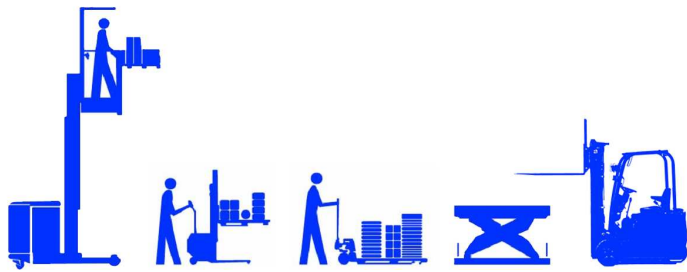

Your task – our solution: special ergonomic equipment (II.)

Galvanized scissor lift trucks, with rotating platform, minilifter with special platform, dustbin tipper

For further information please have a look at our homepage on the internet: www.willecke.de/en



Galvanized lifting table



Lifting table with 4 steering rollers and 2 push handles



Lifting table with 2 foot pumps



Lifting table with pivoting platform



Lifting table with pivoting roller conveyor



Pallet stacker with working platform



Equipment for reel slitters



Mini lifter in stainless steel with box attachment



Electro-hydraulic platform equipment



Mini lifter with crane arm



Mini lifter with mandrel



Mini lifter with clamping device in stainless steel



Mini lifter with prism surface



Mini lifter with tilting platform



Mini lifter with inclined tilting platform



Manual dustbin tipper

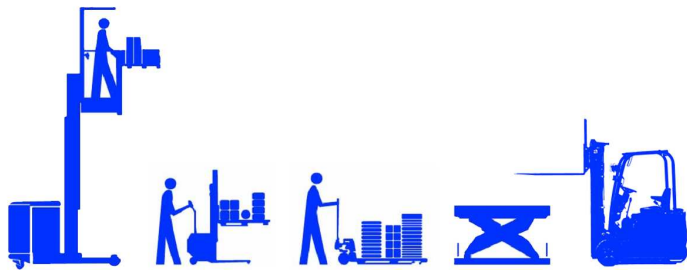

Your task – our solution: special ergonomic equipment (III.)

Scissor lift trucks special platform, spindle belt, assembly lifting tables with special attachment

For further information please have a look at our homepage on the internet: www.willecke.de/en



Double scissor lifting table in stainless steel



Tandem lifting table with prism surface



Tandem pallet truck with inclinable platform



Lifting table with antistatic platform



Tandem scissor lifting table with, 4m platform length



Lifting table with boom and foldable push handle



Scissor lifting table, revolving on place



Pallet truck with spindle-type stabiliser



Lifting table, 12V propulsion and incorporated battery charger



Lifting table with railing, easy to move



Operating table for horses



Lifting table, small size



Light tandem lifting table with self-supporting sub-frame



Galvanized assembly lift table



Assembly lift table with roller conveyor



Lifting table with foot pump and roller conveyor

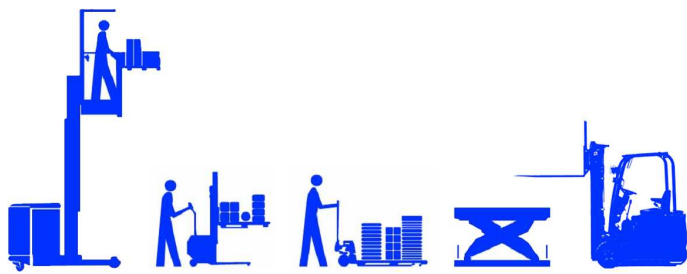

Your task – our solution: lifting tables

Hydraulic lifting tables, push-chain lift, spindle lift, belt lift tables, assembly tables, pallet transfer station

For further information please have a look at our homepage on the internet: www.willecke.de/en



Superlow scissor lifting table, U shaped



Single scissor lifting table



Tandem scissor lifting table



Double scissor lifting table



Lifting table in stainless steel



Superlow lifting table



Low-profile lift table Ergo-E



Scissor lifting table with rigid chain drive



Spindle scissor lifting table



Scissor lifting table with spindle drive



Scissor lifting table with belt drive



System scissor lifting table with belt drive



Assembly table

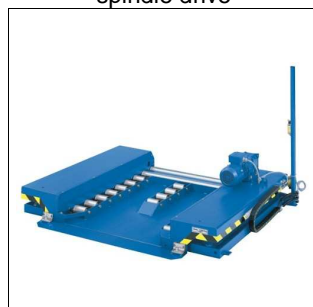

Pallet transfer station



Pallet transfer station



Pallet transfer station

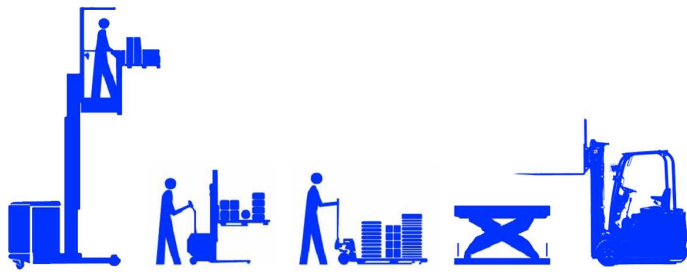

Your task – our solution: special lifting tables (I.)

Assembly tables, heavy-duty lifting tables, ex protected lifting tables, tilt lifting tables, loading lifting tables

For further information please have a look at our homepage on the internet: www.willecke.de/en



Assembly lift table with foot pump and roller conveyor



Lifting table to lift heavy charges



Pneumatic Ex lifting table in stainless steel



Ex lifting table



Scissor lifting table with attachment to tilt



Lifting and tilting table with sub-frame

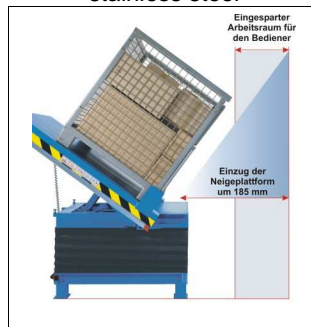

Lifting and tilting table, inclined



Lifting and tilting table with sub-frame



Galvanized loading lifting table with railing and loading gates



Lifting table with railing and roll-away protection



Lifting table with loading ramp



Loading lifting table with railing, wicket and protection



Loading lifting table with loading gates and railing



Lifting table with roll-away protection



Lifting table with non-slip surface

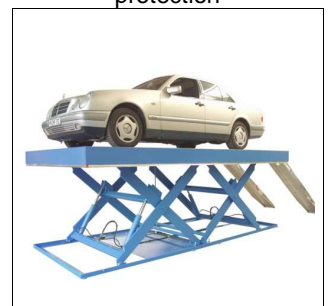

Loading scissor lifting table for car transport with ramp

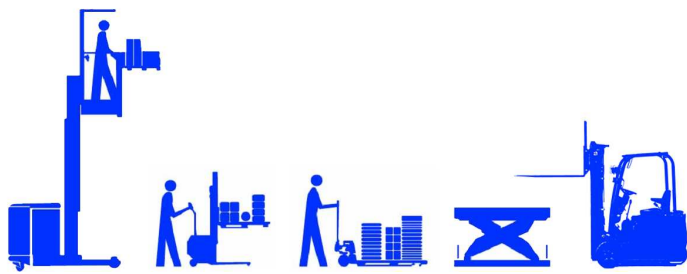

Your task – our solution: special lifting tables (II.)

Double, triple, quadruple scissor lifting table, freight elevators, lifting tables with big platform

For further information please have a look at our homepage on the internet: www.willecke.de/en



Triple scissor lifting table, goods lift



Fourfold scissor lifting table, goods lift



Triple scissor lifting table with rigid chain drive



Double scissor lifting table with rigid chain drive



Heavy duty double scissor lifting table



... with attachment to tilt and sub-frame



Galvanized double scissor lifting table



Double scissor lifting table with roller bearing platform



Tandem loading lifting table with loading gates



Tandem lifting table as working platform



Double tandem lifting table, big size



Tandem lifting table, platform length 14,5m



Tandem lifting table with foot pump



Tandem scissor lifting table with roller conveyor



Lifting table for narrow storage places



Double scissor lifting table with platform to tilt and move

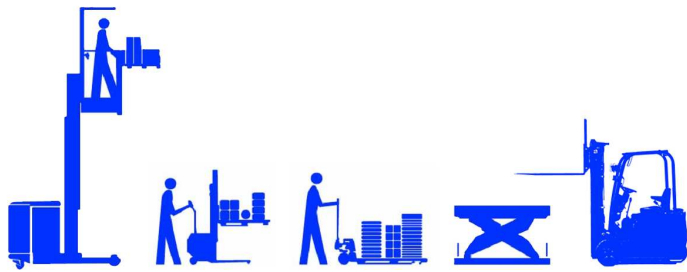

Your task – our solution: special lifting tables (III.)

Working lift tables with superstructures, assembly lifting tables, coil lift trucks, lifting tables with carriage

For further information please have a look at our homepage on the internet: www.willecke.de/en



Lifting table with foot pedal, bellow, upstand as slipp off protection



Lifting table with T-slot plate



Lifting table with 3D working platform



Lifting table with roller bearing platform



Assembly lift table, T-slot plate and interlock support



Assembly lift table with pivoting platform



Double scissor lifting table with pivoting platform



Lifting table system on powered pivoting platform



System lifting table with scale



System lifting table



Lifting table to transport plastic rolls



Lifting table for bales with powered carriage



Lifting table with traction drive - wireless controlled



Lifting table with powered traction drive and bellow



Lifting table with powered rail-bound travelling mechanism



Lifting table with tabletop hood made of stainless steel and traction drive

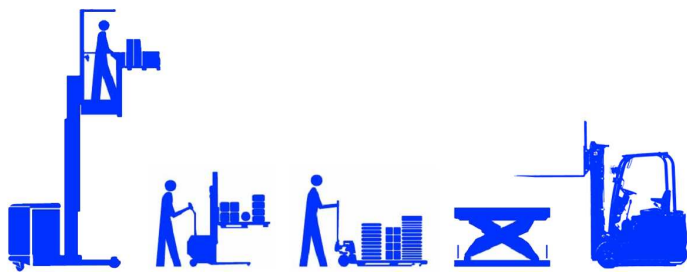

Your task – our solution: special lifting tables (IV.)

Equipment for tilting boxes, lifting tables with traction drive or rather flanged wheels, fixed column lifts, work platform

For further information please have a look at our homepage on the internet: www.willecke.de/en



Electro-hydraulic container tilter



Electro-hydraulic container tilter

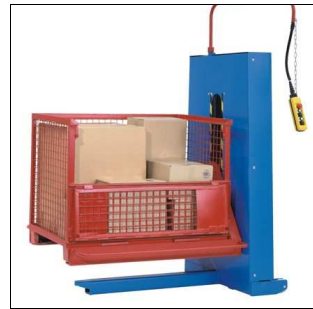

Electro-mechanical container lifter



Electro-mechanical container lifter



Electro-hydraulic container tilter



Fixed lifting and tilting table



Double scissor lifting table with traction drive



Lifting table with traction drive and drawbar



Lifting table with carriage



Lifting table with drawbar



Lifting table with traction drive and platform to move



Lifting table with tabletop hood made of stainless steel and traction drive

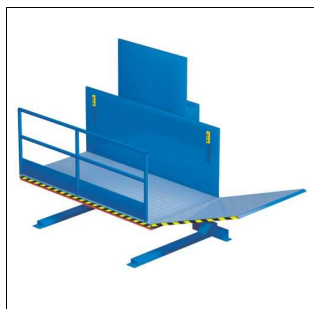

Fixed column lift



Fixed column lift



Fixed column lift with railing



Working platform with staircase

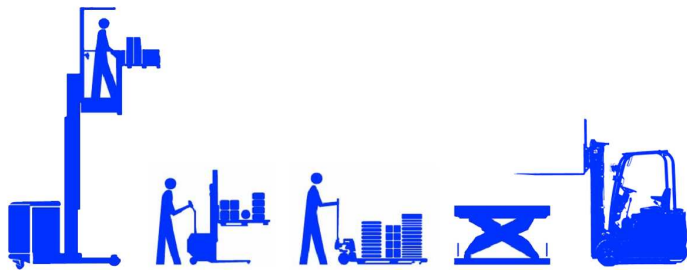

Your task – our solution: special lifting tables (V.)

loading lifting tables, lifting tables with tilting platforms, lifting tables for furnace charge, test desks

For further information please have a look at our homepage on the internet: www.willecke.de/en



Loading lifting table with railing and foldable ramp



Loading lifting table with platform to move



Loading lifting table with foldable grating



Lifting table with prism platform



Lifting table with tilting platform and roller blind



Lifting table with tilting platform



Lifting table platform to pivot and tilt



Lifting and tilting table with rotating platform



Hydraulic lifting table



Scissor lifting table with powered rail-bound travelling mechanism



Lifting table for light charges



Lifting table with C 45 steel plate, 40mm



Lifting table, load bearing capacity 6000kg



Tool replacement truck with platform to move and bellow



Lifting table for loading ovens



Test desk, load bearing capacity 10,000kg

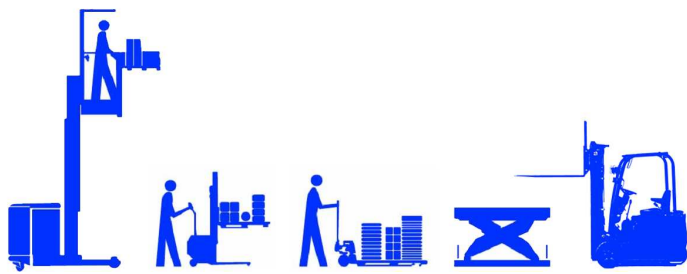

Your task – our solution: stainless steel equipment

Stainless steel pallet truck, stainless steel high lift stacker, stainless steel scissor lift table, stainless steel lifting tables, ex protected equipment

For further information please have a look at our homepage on the internet: www.willecke.de/en



Pallet truck in stainless steel, also available as Ex pallet truck



Pedestrian hand pallet truck in stainless steel



Highlifter in stainless steel



Electric highlifter in stainless steel

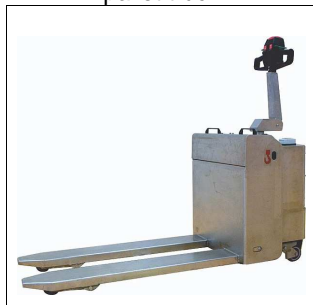

Electric low lift truck



Manual pallet stacker in stainless steel



Manual electric pallet stacker in stainless steel



Electric pallet stacker in stainless steel



Pedestrian tilting pallet truck in stainless steel



Mini lifter in stainless steel with platform



Ex lifting table



Double scissor lifting table in stainless steel



Superlow lifting table in stainless steel



Superlow lifting table in stainless steel



Single scissor lifting table in stainless steel



Double scissor lifting table in stainless steel

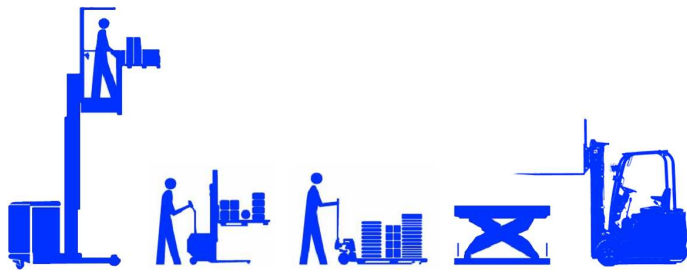

Index	Page
4-way high lift stacker.....	2, 9
AGV equipments.....	9
Assembly lift tables.....	2, 4, 10, 11, 12, 13, 20
Assembly lift tables.....	2, 4, 10, 11, 12, 13, 14, 15
Assembly lift tables for special charges.....	4, 11, 12, 13
Car transporter.....	5
Charging wagon.....	6
Coil lift trucks/coil lifting carriage.....	17
Coil-transporter.....	2, 9
Double scissor lifting tables.....	10, 11, 12, 13, 14, 16, 17, 18, 19, 20
Drawbar high lift stacker.....	1, 2, 5, 6, 7, 8, 9, 10, 20
Drawbar pallet truck.....	1, 2, 5, 8, 20
Drawbar tow tractor.....	2, 7
Driverless transport systems.....	9
Drum handling.....	2, 6, 7
Dustin tipper.....	12
Electric forklifts.....	1, 3
Electric forklift trucks.....	1, 3
Equipments for tilting boxes.....	7, 10, 12, 15, 18, 20
Equipments to grab.....	2, 4, 6, 7, 10
Equipments to pivot.....	2, 5, 6, 7
Equipments to tilt.....	5, 6, 7, 10, 11, 12, 15, 16, 17, 18, 19, 20
Equipments with crane arm.....	7
Ergonomic equipments.....	10, 11, 12, 13, 20
Ex equipments.....	15, 20
Ex high lift stackers.....	20
Ex lifting tables.....	15, 20
Ex pallet trucks.....	20
Fixed column lifts.....	8, 18
Forklifts.....	1, 3
Fourfold lifting tables.....	16
Galvanized lifting tables.....	11
Galvanized lifting tables.....	12, 13, 16, 18
Goods lifts.....	16
Hand pallet trucks.....	1, 10, 20
Handling equipments.....	4, 5, 6, 7, 10, 12, 20
Heavy duty equipments.....	1, 2, 7, 8, 19
Heavy duty lifting tables.....	19
Highlifters.....	10, 20
High lift stackers.....	1, 2, 4, 5, 6, 7, 8, 9, 10, 20

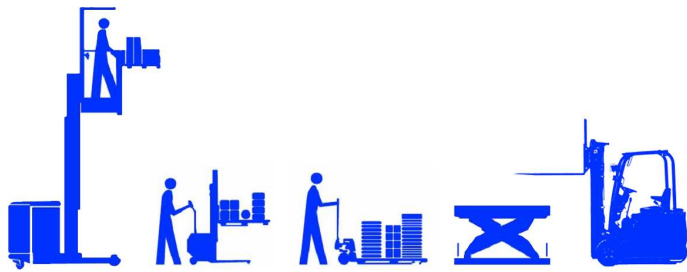

High lift stackers to load special charges.....	2, 4, 5, 6, 7, 8, 9, 10, 12
High lift stackers with hollow.....	5
High lift stackers with pivoting crane arm.....	6
Hydraulic lifting tables.....	4, 10, 11, 12, 13, 14, 15, 16, 17, 18, 19, 20
Lifting tables.....	10, 11, 12, 13, 14, 15, 16, 17, 18, 19, 20
Lifting tables for loading ovens.....	19
Lifting tables with belt drive.....	14
Lifting tables with big platform.....	16
Lifting tables with carriage.....	10, 11, 12, 13, 17, 18, 19
Lifting tables with flanged wheels.....	18
Lifting tables with rigid chain.....	14
Lifting tables with roller bearing platforms.....	4, 11
Lifting tables with roller conveyors.....	4, 10, 11, 12
Lifting tables with rotating platforms.....	11, 12
Lifting tables with special platforms.....	4, 11, 12, 13
Lifting tables with tilting platforms.....	11, 13, 15, 16, 17, 18, 19
Lifting tables with traction drive.....	17, 18, 19
Lifting work frames.....	8, 18
Loading lift tables.....	15, 16, 19
Low level pickers.....	3
Low lifters.....	1, 5, 8, 9, 20
Mandrel high lift stacker.....	4, 5, 12
Manual high lift stackers.....	1, 2, 4, 5, 6, 10, 11, 12, 13, 20
Mini lifters.....	10, 12, 20
Mini lifters for special charges.....	12
Order pickers.....	3
Pallet stackers.....	1, 2, 3, 4, 6, 8, 9, 10, 20
Pallet transfer stations.....	14
Pallet trucks.....	1, 10, 20
Pedestrian stacker.....	1
Platforms to move.....	11, 16, 18, 19
Prism equipments.....	8
Reel clamps.....	5, 6, 7
Remote control.....	9
Roller grab.....	5
Stainless steel high lift stacker.....	20
Self-supporting high lift stacker.....	1, 3
Self-supporting stackers.....	1, 3
Scissor lifting tables.....	10, 11, 12, 13, 20
Scissor lifting tables.....	10, 11, 12, 13, 14, 15, 16, 17, 18, 19, 20
Sideloader.....	2, 9
Sit-on high lift stackers.....	1, 2, 8, 9
Sit-on low lifters.....	1, 8, 9

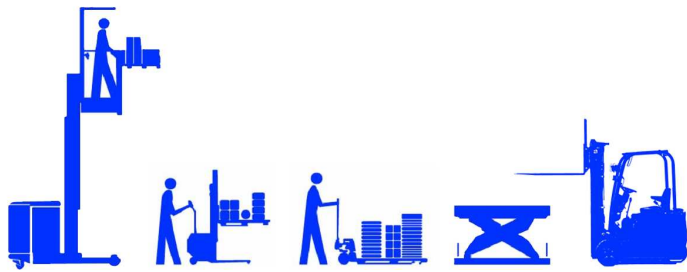

Spindle belt.....	13
Spindle lifting tables.....	14
Sprinter high lift stacker.....	10
Stainless steel lifting tables.....	20
Stainless steel pallet truck.....	20
Stainless steel scissor lift trucks.....	13, 20
Stand-on stackers.....	1, 2, 3, 9
Stackers.....	1, 3
Superlow lifting tables.....	14
Superlow lifting tables, U-shaped.....	14
Tandem lifting tables.....	13, 14, 15, 16 18
Telescoping forks.....	3, 8
Test desks.....	19
Tilting lifting tables.....	11, 15, 16, 18, 19
Tilting platforms.....	15
Tool replacement trucks.....	2, 4, 10, 11, 12, 13
Tow tractors.....	2, 5, 7
Traction drives.....	8
Triple scissor lifting table.....	16
Very narrow aisle truck.....	3
Working lift tables with superstructures.....	16
Working platform.....	15, 16, 18



**Willecke Hebe- und Fördergeräte
GmbH
An der Becke 7 (Gewerbegebiet Ludwigstal I)
D-45527 Hattingen**

Tel.: +49 (0) 2324 / 39 112 - 0

Fax: +49 (0) 2324 / 39 112 - 22

E-Mail: info@willecke.de

www.willecke.de/en